



William F. Martin  
Mayor

City of  
**GREENFIELD, MASSACHUSETTS**

---

**DEPARTMENT OF PUBLIC WORKS**

189 Wells Street, Greenfield, MA 01301  
Phone 413-772-1528 • Fax 413-773-9593  
DPW@greenfield-ma.gov • www.greenfield-ma.gov

**INVITATION FOR BIDS**

The City of Greenfield, Massachusetts will accept sealed bids for furnishing and delivering for use by the City of Greenfield, Department of Public Works:

**Materials for Pickett Lane Forced Sewer Main – Bid #DPW 19-26**

Sealed Bids addressed to the Department of Public Works, 189 Wells Street, Greenfield, Massachusetts and endorsed “*Materials for Pickett Lane Forced Sewer Main, DPW 19-26*” will be accepted by the Department of Public Works in the new administration building. Bids will be accepted until 2:00 p.m. on Thursday, April 4, 2019, at which time said bids will be publicly opened and read aloud in the Administration Building Meeting Room located at 189 Wells St.

Bidding/contract documents will be emailed upon request by contacting [alan.twarog@greenfield-ma.gov](mailto:alan.twarog@greenfield-ma.gov) or by downloading them from the City’s Purchasing Department’s webpage at <https://greenfield-ma.gov/p/1815/Current-FY19-IFBRFPRFQRF>. To get on the Bidder’s List, proposers should contact Alan Twarog at [alan.twarog@greenfield-ma.gov](mailto:alan.twarog@greenfield-ma.gov).

A 50% Labor and Materials (Payment) Bond will be required of the successful bidder.

Bids are subject to the provisions of the Massachusetts General Laws Chapter 30B, Section 5.

The City of Greenfield reserves the right to accept or reject any or all proposals if the City deems it in the public interest or in the interest of the City to do so.

The bid/contract awarding authority is the City of Greenfield, Department of Public Works.

---

Please advertise March 20<sup>th</sup> and March 27<sup>th</sup>, 2019 Adv: Recorder

## **INFORMATION FOR BIDDERS**

Section 1.0 Information for Bidders:

- 1.1 The scope of this contract consists of furnishing all of the required materials, with its required parts and supplies necessary for or pertinent to the installation of the material by the City of Greenfield, Massachusetts, Department of Public Works in accordance with the specifications included herein.
- 1.2 The material supplied shall conform to standards prescribed or approved within these specifications. Any reference to a specification or designation of the American Water Works Association (AWWA) or Massachusetts Department of Public Works Specification, refers to the most recent or latest specifications or designation. Where names of specific products may be designated in these specifications, the intent is to state the general type and quality of product desired without ruling out use of other products of equal type and quality which have been approved in writing by the owner.
- 1.3 Guarantee: The bidder hereunder guarantees their respective material against defective materials or workmanship for a period of twelve (12) months from date of delivery by the bidder and acceptance by the owner.
- 1.4 Questions regarding Documents: In general, no answer will be given to prospective bidders in reply to an oral question if the question involves an interpretation of the intent or meaning of the contract documents, or the equality specifications. Any information given to bidders, other than by means of contract documents, including Addenda, as described below, is given for information and convenience of the bidder only and is not guaranteed. The bidder agrees that such information does not entitle the bidder to assert any claim or demand against the owner or the engineer on account thereof.

To receive consideration, such questions shall be submitted in writing to the owner at least three days before the established date for receipt of bids. If the question involves the equality or use of products or methods, it must be accompanied by drawings, specifications, or other data in sufficient detail to enable the owner to determine the equality or suitability of the products or methods. In general, the owner will neither approve nor disapprove particular products prior to the opening of bids.

The owner will set forth, as Addenda, which shall become a part of the contract documents, such questions received as above provided as in his sole judgment, are appropriate or necessary and his decision regarding each. At least two days prior to the receipt of bids, he will send a copy of these Addenda to those prospective bidders known to have taken out sets of the contract documents.

- 1.5 Blank Form for Bid: All bids must be upon the blank form for bid annexed hereto, state the proposed price of each item, both in words and in figures, and be signed by the bidder with his business address and place of residence. Bidders shall not remove and submit the bid pages separate from the volume of contract documents, but shall submit their bids bound with the complete volume of attached contract documents, including all pages correctly assembled.

- 1.6 Withdrawal of Bids: Except as hereinafter in this subsection otherwise expressly provided, once his bid is submitted and received by the owner for consideration and comparison with other bids similarly submitted, the bidder agrees that he may not and will not withdraw it within 40 consecutive calendar days after the actual date of the opening of bids.

Upon proper written request, and identification, it may be withdrawn only as follows:

1. At any time prior to the designated time for opening of bids.
2. Provided the bid has not been accepted by the owner, at any time subsequent to the expiration of the period during which the bidder has agreed not to withdraw his bid.

Unless a bid is withdrawn as provided above, the bidder agrees that it shall be deemed open for acceptance until the Agreement has been executed by both parties thereto or until the owner notified a bidder, in writing, that his bid is rejected or that the owner does not intend to accept it. Notice of acceptance of a bid shall not constitute rejection of any other bid.

- 1.7 Ability and Experience of Bidder: No award will be made to any bidder who cannot satisfy the owner that he has sufficient ability and experience in this class of work and sufficient capital and plant to enable him to prosecute and furnish the material within a normal period of time. The owner's decision or judgment on these matters shall be final, conclusive, and binding.

The owner may make such investigations as it deems necessary, and the bidder shall furnish to the owner, under oath, if so required, all such information and data for this purpose as the owner may request.

- 1.8 Bids: The owner, in its sole judgment, may reject bids which are incomplete, conditional, obscure or not responsive or which contain additions not called for, erasures not properly initialed, alterations, or similar irregularities or the owner may waive such omissions, conditions, or irregularities.

The City of Greenfield reserves the right to reject any or all bids wholly or in part; to waive technicalities and informalities; to amend and/or cancel bid prior to the time of opening; to make awards in a manner deemed best to the City; and to correct any award erroneously made as a result of a clerical error on the part of the City.

- 1.9 Execution of Agreement: The bidder whose bid is accepted will be notified by letter and agrees to duly execute the Agreement.
- 1.10 Unit Prices: Only firm unit prices will be accepted. Any bid proposals containing escalator clauses or any other such provisions will be rejected as unsuitable for consideration.
- 1.11 Delivery: All prices shall be F.O.B. City of Greenfield, Department of Public Works, Greenfield, Massachusetts. All shipping charges are to be prepaid by the bidder. The City of Greenfield's purchases are tax exempt under the number #E-046-001-163.
- 1.12 Comparison of Bids: Bids will be compared and awarded on the basis of each individual items unit price stated in the bid.

In the event that there is a discrepancy in the bid between the unit prices written in words and figures, prices written in words shall govern.

The owner agrees to examine and consider each bid submitted in consideration of the bidder's agreements, as hereinabove set forth and as set forth in the bid.

- 1.13 Questions Regarding Specifications: All questions relative to the specifications shall be directed to:

Alan Twarog  
189 Wells Street  
Greenfield, MA 01301  
413-772-1528 x6104

- 1.14 Exceptions to Specifications: Bidders are to list exceptions of any and all material, item or design specifications in their bid, in detail, and further, to select and qualify each exception using one of the following categories:.

Category A – As specified

Category B – Material, item or design in specification is not available to the bidder from any source.

Category C – Material, item or design in specification is available to bidder from some source, but bidder chooses not to offer material, item or design at this time for this bid.

Category D – The bidder chooses to offer in lieu of the material, item or design, as detailed in attachment to this bid.

- 1.15 Disputes: In the event of any dispute as to any of the terms and conditions of this contract, it shall be determined in accord with the laws of the Commonwealth of Massachusetts and the Courts of the Commonwealth of Massachusetts shall have exclusive jurisdiction of the same.

- 1.16 Bid Enclosures: Manufacturers specifications must be enclosed with the bid proposal.

- 1.17 Rule for Award: The contract will be awarded to the responsive and responsible bidder offering the lowest total price for all items.

**FORMS FOR BID**

\_\_\_\_\_  
Bidder's Name

**PROPOSAL FORM**

To the City of Greenfield, Massachusetts, (hereinafter called the "Owner") acting through its Department of Public Works, duly authorized therefore, who act solely for said City and without personal liability to themselves:

Gentlemen:

The undersigned \_\_\_\_\_, as bidder, declares that the only persons or parties interested in this bid as principals are those named herein; that the bidder has carefully examined the proposed form of Proposal and the specifications (and amendments thereto); and he bids and agrees, if this bid is accepted, that the bidder will furnish the material specified in the Proposal, in the manner and time therein prescribed and according to the requirements of Owner as herein set forth.

The bidder agrees that the Owner will have forth (40) consecutive days from date of bid opening to accept and order, except as described in the specifications, the unit(s) at the price, therein. The bidder also understands that the owner reserves the right to accept or reject any or all bids and to waive any informalities in the proposals if it is in the Owner's interest to do so. The Invitation for Bids, Information for Bidders, Specifications and Proposal Form attached thereto, shall become a contract upon the receipt by the bidder of written acceptance of this bid by the owner.

The bidder will take in full payment, therefore, the following price, to wit:

Item Number	Estimated Quantity	Brief Description; unit or lump sum price bid in both words and figures	Total in Figures
1.	1400 L.F.	2" SDR 11 HDPE Low Pressure Sewer Main  _____ dollars and _____ cents (\$_____)	\$_____
2.	583 L.F.	1.25" SDR 11 HDPE Service Lateral Pipe  _____ dollars and _____ cents (\$_____)	\$_____

3.	2 EA.	90 Degree Elbows for 2" SDR 11 HDPE Low Pressure Sewer Main	_____ dollars	and _____ cents (\$ _____)	\$ _____
4.	20 EA.	Corp Stops	_____ dollars	and _____ cents (\$ _____)	\$ _____
5.	20 EA.	Lateral Kits (Curb Stops) with Curb Boxes	_____ dollars	and _____ cents (\$ _____)	\$ _____
6.	2 EA.	Clean Outs for installation in Sewer Manholes	_____ dollars	and _____ cents (\$ _____)	\$ _____

The total price for Items \_\_\_\_\_ inclusive, derived as described in the INFORMATION FOR BIDDERS under the heading "Comparison of Bids," is \$\*\* \_\_\_\_\_.

This BID includes Addenda number \*\*\* \_\_\_\_\_.

\*\* Bidder must fill in this blank

\*\*\* To be filled in by Bidder if Addenda are issued.



\_\_\_\_\_  
Name of Bidder

(SEAL)

By \_\_\_\_\_  
(Signature and title of authorized representative)

\_\_\_\_\_  
(Business Address)

\_\_\_\_\_  
(City & State)

Date \_\_\_\_\_

The Bidder is a corporation incorporated in the State (or Commonwealth) of \_\_\_\_\_  
\_\_\_\_\_  
(Bidder must add and delete, as necessary, to make this sentence read correctly).

(Note: If the Bidder is a corporation, affix corporate seal and give below the names of its president, treasurer, and general manager, if any; if a partnership, give full names and residential addresses of all partners, and if an individual, give residential address if different from business address.)

**TAX COMPLIANCE/NON-COLLUSION FORM**

Bid No. \_\_\_\_\_ for \_\_\_\_\_

The undersigned certifies under penalties of perjury that this bid has been made and submitted in good faith and without collusion or fraud with any other person. As used in this certification, the word "person" shall mean any natural person, business, partnership, corporation, union, committee, entity, or group of individuals.

\_\_\_\_\_  
(Name of person signing Bid or Proposal)

\_\_\_\_\_  
(Name of business)

Pursuant to M.G.L. Ch. 62C, Sec. 49A, I certify under the penalties of perjury that I, to the best of my knowledge and belief, am in compliance with all laws of the Commonwealth relating to taxes, reporting of employees and contractors, and withholding and remitting child support.

\_\_\_\_\_  
Social Security Number

\_\_\_\_\_  
Signature of Individual or Corporate Name

By: \_\_\_\_\_  
Corporate Officer  
(if applicable)

Any person or corporation that fails to execute these attestation clauses shall not be awarded this bid.

Submission of a social security or federal identification number is voluntary.

**NOTARIZED STATEMENT**

I, (name) \_\_\_\_\_

(title) \_\_\_\_\_

of (company) \_\_\_\_\_

of (address) \_\_\_\_\_

(phone #) \_\_\_\_\_

do hereby certify that the information contained herein is true, accurate and correct, to the best of my knowledge. It is agreed that any and all merchandise to be delivered hereunder, will be in conformity with the specifications set forth, including any and all amendments thereto.

Witness my hand and seal this \_\_\_\_\_ day of

\_\_\_\_\_, 20\_\_.

\_\_\_\_\_  
Witness

\_\_\_\_\_  
Signature

State of \_\_\_\_\_

\_\_\_\_\_, ss. \_\_\_\_\_, 20\_\_

Personally appeared the above named \_\_\_\_\_  
and acknowledged the foregoing statement to be true, to the best of his/her knowledge, before  
me.

\_\_\_\_\_  
Notary Public

My commission expires: \_\_\_\_\_

## **AGREEMENT**

**AGREEMENT FOR CONTRACT DPW 19-26**

**Materials for Pickett Lane Forced Sewer Main**

**THIS AGREEMENT**, executed this \_\_\_\_\_ day of \_\_\_\_\_  
in the year Two Thousand and Nineteen.

(herein referred to as the “AGREEMENT”), by and between the City of Greenfield, Massachusetts, acting by and through its Department of Public Works, duly authorized therefore, which acts solely for said City and without personal liability to itself, party of the first part, and \_\_\_\_\_ party of the second part.

WITNESSETH, that the parties to these presents, each in consideration of the undertakings, promises, and agreements on the part of the other herein contained, have undertaken, promised and agreed and do hereby undertake, promise, and agree, the party of the first part for itself, its successors and assigns, and the party of the second part for himself and his heirs, executors, administrators, successors and assigns, as follows:

The Contractor agrees to furnish all equipment, machinery, tools and labor, to furnish and deliver all materials required to be furnished and delivered in and about the improvement and to do and perform all work in accordance with the specifications and conditions attached hereto and made a part hereof, in strict conformity with the provisions herein contained and the Advertisement for Bidders, Information for Bidders, Proposal, and General, Supplemental and Special Conditions hereto annexed. All said Advertisement for Bidders, Information for Bidders, Proposal, and General, Supplemental and Special Conditions are hereby specifically made a part of this contract as fully and to the same effect as if the same had been set forth at length herein.

In consideration of the foregoing premises, the Owner agrees to pay and the Contractor agrees to receive as full compensation for everything furnished and done by the Contractor under this contract; including all work required, for all loss or damage arising out of the nature of the work aforesaid, or from the action of the elements, or from any delay or from any unforeseen obstruction or difficulty encountered in the prosecution of the work, and for all risks of every description connected with the work, and for all expenses incurred by or in consequence of the suspension or discontinuance of the work as herein specified, and for well and faithfully completing the work, and the whole thereof, as herein provided, such price or prices as are set out in the accompanying proposal, and for all work required, for which there is no item in the proposal, such compensation as is provided for in the aforesaid specifications.

The Contractor’s bid price for this project is \_\_\_\_\_.

IN WITNESS WHEREOF, the Owner has caused this instrument to be signed and its corporate seal to be hereto affixed in its behalf, and the Contractor has caused this instrument to be signed in its behalf.

**AGREEMENT FOR CONTRACT DPW 19-26**

**Materials for Pickett Lane Forced Sewer Main**

FOR THE OWNER,

\_\_\_\_\_

By the \_\_\_\_\_

\_\_\_\_\_

FOR THE CONTRACTOR,

Witness: \_\_\_\_\_

\_\_\_\_\_

\_\_\_\_\_

By the \_\_\_\_\_

\_\_\_\_\_

(If a corporation, attach to each signed Agreement a notarized copy of the corporate vote authorizing the signatory to sign this Agreement.)

Approved as to Appropriation:

\_\_\_\_\_  
City Accountant

**Certificate of Acknowledgment of Contractor if a Corporation**

**For AGREEMENT**

State of \_\_\_\_\_ )

SS:

County of \_\_\_\_\_ )

On this \_\_\_\_\_ day of \_\_\_\_\_, 20\_\_,

before me personally came \_\_\_\_\_

to me known, who being by me duly sworn, did depose and say as follows:

That he resides at \_\_\_\_\_

and is the \_\_\_\_\_

of \_\_\_\_\_

the corporation described in and which executed the foregoing instrument; that he knows the corporate seal of said corporation; that the seal affixed to the foregoing instrument is such corporate seal and it was so affixed by order of the Board of Directors of said corporation; and that by the like order he signed thereto his name and official designation.

\_\_\_\_\_  
Notary Public (Seal)

My commission expires: \_\_\_\_\_

**LABOR AND MATERIALS (PAYMENT) BOND**



**LABOR AND MATERIALS (PAYMENT) BOND**

KNOW ALL MEN BY THESE PRESENTS:

That we, \_\_\_\_\_  
\_\_\_\_\_  
(an individual, a partnership, a corporation)

duly organized under the Laws of the State (or Commonwealth) of \_\_\_\_\_,  
and having a usual place of business at \_\_\_\_\_,  
as Principal, and \_\_\_\_\_, a corporation  
duly organized under the Laws of the State (or Commonwealth) of \_\_\_\_\_,  
and having a usual place of business at \_\_\_\_\_,  
as Surety, are holden and stand firmly bound and obligated unto the City of Greenfield,  
Massachusetts, as obligee, in the sum of \_\_\_\_\_,  
lawful money of the United States of America to and for the true payment whereof we bind  
ourselves and, each of us, our heirs, executors, administrators, successors, and assigns, jointly  
and severally, firmly by these presents.

WHEREAS, the Principal, by means of a written AGREEMENT (which together with the  
Contract Documents in said AGREEMENT referred to are collectively sometimes referred to as  
the "Contract") dated \_\_\_\_\_.

Has entered into a contract with the said obligee for \_\_\_\_\_  
\_\_\_\_\_

a copy of which AGREEMENT is attached hereto and by reference made a part hereof.

NOW, THEREFORE, THE CONDITION of this obligation is such that if the Principal shall promptly make payments to all claimants as hereinafter defined, for all labor performed or furnished and for all materials and equipment furnished for or used or in connection with the Work called for by said AGREEMENT and/or Contract and any modifications thereof, including lumber used, but not incorporated in said Work, and for the rental or hire of vehicles, tools and other appliances and equipment furnished for or used in connection with said Work, this obligation shall be void; otherwise it shall remain in full force and effect, subject, however, to the following conditions:

1. A claimant is defined as one having a direct contract with the Principal or with a subcontractor of the Principal for labor, materials, and/or equipment used or

reasonably required for use in the performance of the said Work, labor and materials, being construed to include that part of water, gas, power, light, heat, oil, gasoline, telephone service or rental of equipment directly applicable to the said AGREEMENT and/or Contract and any modifications thereof.

2. The above named Principal and Surety hereby jointly and severally agree with the City that every claimant as herein defined, who has not been paid in full before the expiration of a period of ninety (90) days after the date on which the last of such claimant's work or labor was done or performed, or materials or equipment were furnished by such claimant, may sue on this bond for the use of such claimant, prosecute the suit to final judgment for such sum or sums as may be justly due claimant, and have execution thereon. The City shall not be liable for the payment of any costs or expenses of any such suit.
3. No suit or action shall be commenced hereunder by a claimant,
  - (a) Unless claimant, other than one having a direct contract with the Principal, shall have given written notice to any two of the following: The Principal, the City or the Surety above named, within ninety (90) days after such claimant did or performed the last of the work or labor, or furnished the last of the materials or equipment for which said claim is made, stating with substantial accuracy the amount claimed and the name of the party to whom the materials or equipment were furnished, or for whom the work or labor was done or performed. Such notice shall be served by mailing the same by registered mail or certified mail, postage prepaid, in an envelope addressed to the Principal, City, or Surety at any place where an office is regularly maintained for the transaction of business, or served in the state in which the said Work is located, save that such service need not be made by a public officer;
  - (b) After the expiration of one (1) year following the date on which the Principal ceased work on said AGREEMENT and/or Contract and any modifications thereof, it being understood, however, that if any limitation shall be deemed to be amended so as to be equal to the minimum period of limitation permitted by such law.
  - (c) Other than in a state court of competent jurisdiction in and for the county or other political subdivision of the state in which the said Work, or any part thereof, is situated, or in the United States District Court for the district in which the said Work, or any part thereof, is situated, and not elsewhere.
4. The amount of this bond shall be reduced by and to the extent of any payment or payments made in good faith hereunder, inclusive of the payment by Surety of mechanics liens which may be filed of record against said AGREEMENT and/or Contract or said Work, whether or not claim for the amount of such lien be presented under and against this bond.

The Surety, for value received, agrees further that no changes in, omissions from, or alterations, modifications or additions to the terms and provisions of said AGREEMENT and/or Contract or the Work to be performed thereunder, and that no extensions of time given or changes made in the manner or time of making payments thereunder, shall in any way affect the Surety's obligations on this Bond, and the Surety hereby waives notice of any such changes, omissions, alterations, modifications, additions or extensions.

IN WITNESS WHEREOF, we have hereunto set our hands and seals to \_\_\_\_\_ counterparts of this Bond, this \_\_\_\_\_ day of \_\_\_\_\_ in the year Two Thousand and Nineteen.

\_\_\_\_\_  
Principal (Seal)

\_\_\_\_\_  
Principal (Seal)

\_\_\_\_\_  
Principal (Seal)

\_\_\_\_\_  
Surety (Seal)

\_\_\_\_\_  
Surety (Seal)

\_\_\_\_\_  
Surety (Seal)

(NOTE: If the Principal (Contractor) is a partnership, the Bond should be signed by each of the partners.

If the Principal (Contractor) is a corporation, the Bond should be signed in its correct corporate name by its duly authorized officers.

If this Bond is signed on behalf of the Surety by an attorney-in-fact, there should be attached to it a duly certified copy of his power of attorney showing his authority to sign such Bonds.

There should be executed an appropriate number of counterparts of the Bond corresponding to the number of counterparts of the AGREEMENT.)

**Certificate of Acknowledgment of Contractor if a Corporation**  
**For CONTRACT BONDS**

State of \_\_\_\_\_ )  
County of \_\_\_\_\_ ) SS:

On this \_\_\_\_\_ day of \_\_\_\_\_, 20\_\_\_\_,  
before me personally came \_\_\_\_\_  
to me known, who being by me duly sworn, did depose and say as follows:

That he resides at \_\_\_\_\_  
and is the \_\_\_\_\_  
of \_\_\_\_\_

the corporation described in and which executed the foregoing instrument; that he knows the corporate seal of said corporation; that the seal affixed to the foregoing instrument is such corporate seal and it was so affixed by order of the Board of Directors of said corporation; and that by the like order he signed thereto his name and official designation.

\_\_\_\_\_  
Notary Public (Seal)

My commission expires: \_\_\_\_\_

## **SPECIFICATIONS**

# STAINLESS STEEL LATERAL ASSEMBLY NO FITTINGS

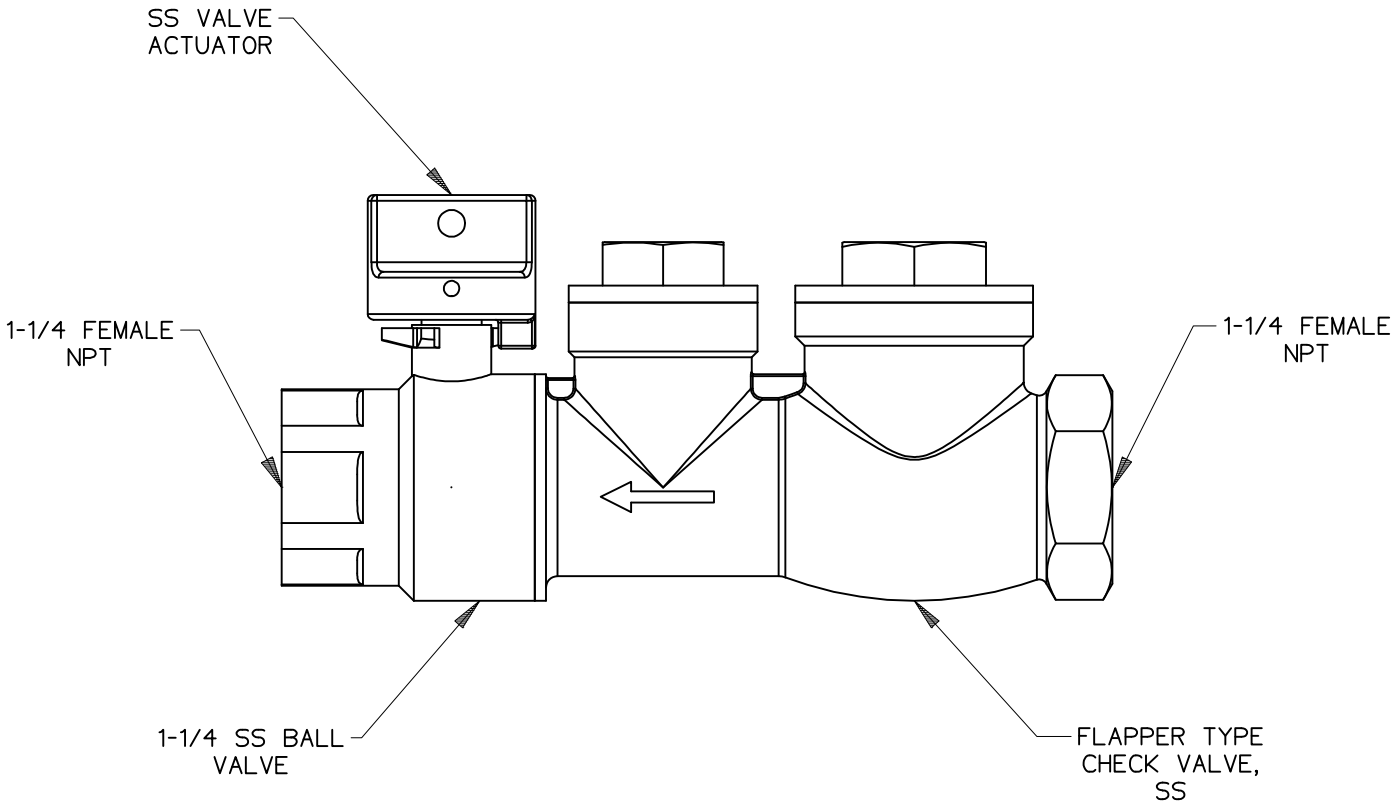

PART IS A BALL VALVE CURB STOP WITH FEMALE PIPE THREADS,  
VALVE POSITION STOPS (OPEN/CLOSED), AND INTEGRAL CHECK VALVE  
MATERIAL: STAINLESS STEEL

PRESSURE RATING: 235 PSI

TO ORDER SS LATERAL, NO FITTINGS  
USE PART NUMBER NB0184P01

**NOTES:**

1. FOR SS FITTING INTO SS THREAD, USE PIPE DOPE OR TEFLON TAPE, NOT BOTH
2. FOR PLASTIC FITTINGS INTO SS THREAD, USE BOTH PIPE DOPE AND 2 LAYERS OF TEFLON TAPE

SGS	DN	09/20/11	A	3/16
DR BY	CHK'D	DATE	ISSUE	SCALE



STAINLESS STEEL LATERAL ASSEMBLY  
NO FITTINGS

NA0330P05

# STAINLESS STEEL LATERAL KIT 1-1/4" SDR 11 HDPE PIPE

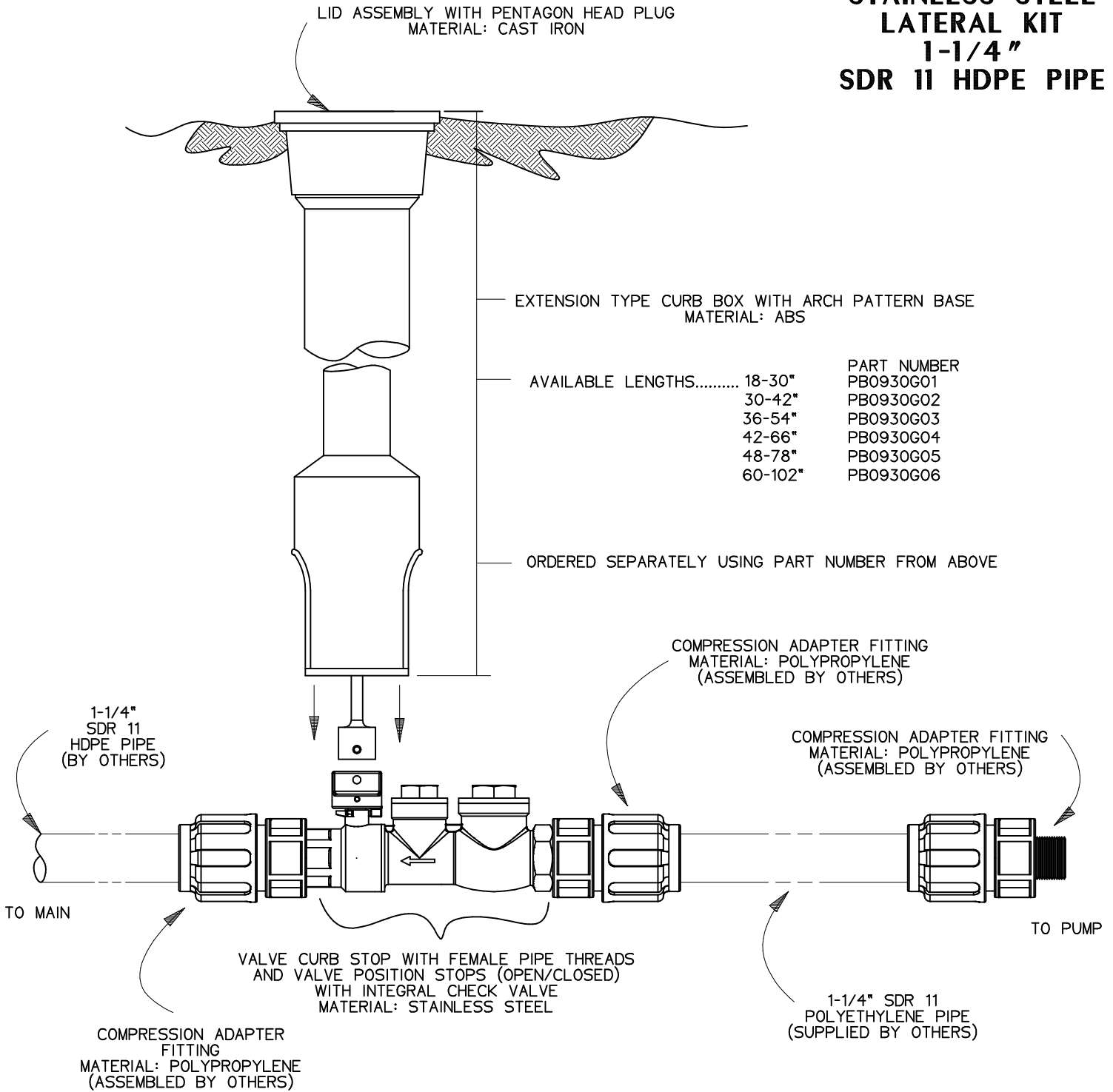

**NOTES:**

1. SS CURB STOP/CHECK VALVE AND FITTINGS ARE PROVIDED SEPARATELY, TO BE ASSEMBLED BY OTHERS
2. TO ASSEMBLE, APPLY A DOUBLE LAYER OF TEFLON TAPE, AND A LAYER OF PIPE DOPE (SUPPLIED BY OTHERS) TO THE THREADS ON THE PLASTIC FITTINGS AND INSTALL PER THE MANUFACTURER'S INSTRUCTIONS  
\*FOR SS FITTING INTO SS THREAD, USE PIPE DOPE OR TEFLON TAPE, NOT BOTH
3. ASSEMBLY IS TO BE PRESSURE TESTED (BY OTHERS)
4. ASSEMBLY IS TO BE USED WITH SDR11 HDPE PIPE
5. TO ORDER SS LATERAL KIT, USE PART NUMBER NCO193G01
6. CURB BOX IS TO BE ORDERED SEPARATELY, SEE ABOVE

KIT PARTS ARE NOT ASSEMBLED

SGS	DN	11/02/11	B	3/16
DR BY	CHK'D	DATE	ISSUE	SCALE
				
STAINLESS STEEL LATERAL KIT 1-1/4" SDR 11 HDPE PIPE				
NA0330P02				

# **E/ONE**

---

# **EXTREME**

S E R I E S

---

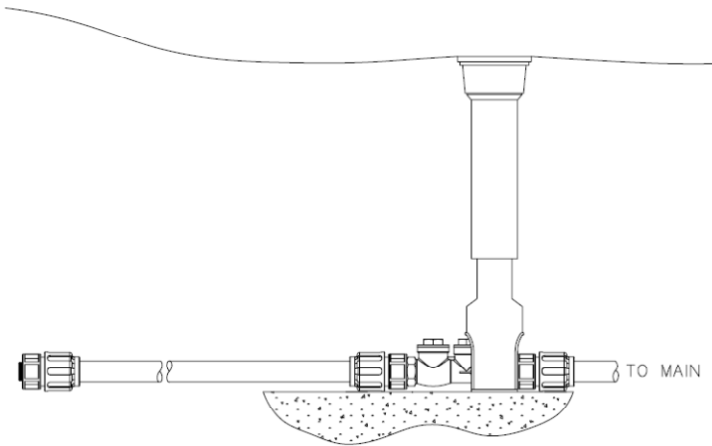

**Stainless Steel &  
Engineered  
Thermoplastics**

## **Typical Specifications**

**Uni-Lateral:  
Stainless Steel  
Forced Sewer Main  
Service Lateral Kits  
SDR HDPE Pipe**

**(Compression  
Fitting)**



**SPECIFICATION:  
SERVICE LATERAL KIT WITH STAINLESS STEEL VALVES AND  
ENGINEERED THERMOPLASTIC COMPRESSION FITTINGS**

## **1.0 GENERAL**

- 1.01 GENERAL DESCRIPTION:** The **MANUFACTURER** shall furnish Uni-Lateral service lateral kits (exclusive of piping), each consisting of three (3) compression fittings, one (1) combination curb stop/check valve assembly and one (1) curb box. The curb stop/check valve assembly shall be 316 stainless steel and have a two-piece cast 316 stainless steel housing, creating a unilateral body. All plastic compression fittings are to be molded from polypropylene and shall be tested for resistance to aging, pressure rating, tensile strength, and flexural strength. All components shall incorporate compression fitting connections for easy, reliable installation of piping. The lateral kit shall be rated for 150 psi service. Lateral kits with pressure-tested combination curb stop/check valve assembly shall be provided by Environment One Corporation, Niskayuna, New York, or approved equal. E/One requires that an E/One Uni-Lateral assembly (E/One part number NB0184PXX or NC0193GXX) or E/One Redundant Check Valve (E/One part number PC0051GXX) be installed in the pipe lateral outside the home between the pump discharge and the street main on all installations.
- 1.02 SHOP DRAWINGS:** After receipt of notice to proceed, the **MANUFACTURER** shall furnish an electronic set of shop drawings that details the equipment to be furnished, including dimensional data and materials of construction. The **SPECIFYING ENGINEER** shall promptly review this data and return two (2) copies as accepted, or with requested modifications. Upon receipt of accepted shop drawings, the **MANUFACTURER** shall proceed immediately with fabrication of the equipment.
- 1.03 WARRANTY:** All merchandise is warranted to be free from defects in materials and factory workmanship. Environment One shall provide, free of charge, new products in equal quantities for any that prove defective within two (2) years from date of shipment from the factory. The **MANUFACTURER** shall not be liable for any loss, damage, or injury, direct or consequential, arising out of the use of or the inability to use the product. Before using, the user shall determine the suitability of the product for his intended use and user assumes all risk and liability whatever in connection therewith. No claims for labor or consequential damage will be allowed. The foregoing may not be changed except by agreement signed by an officer of the **MANUFACTURER**.

## **2.0 PRODUCT**

- 2.01 ENGINEERED THERMOPLASTIC FITTINGS:** All plastic fitting components are to be in compliance with applicable ASTM standards.

All pipe connections shall be made using compression fitting connections including a Buna-N O-ring for sealing to the outside diameter of the pipe. A split-collet locking device shall be integrated into all pipe connection fittings to securely restrain the pipe from hydraulic pressure and external loading caused by shifting and settling.

- 2.02 STAINLESS STEEL UNI-LATERAL CURB STOP/CHECK VALVE ASSEMBLY:** The Uni-Lateral shall be pressure-tight in both directions. The ball valve actuator shall include position stop features at the fully opened and closed positions. The curb stop/check valve assembly shall be designed to withstand a working pressure of 235 psi.

The stainless steel check valve shall be integral with the curb stop valve. The check valve will provide a full-ported 1-1/4" passageway and shall introduce minimal friction loss at maximum rated flow. The flapper hinge design shall provide a maximum degree of freedom and ensure seating at low back pressure.

- 2.03 CURB BOXES:** Curb boxes shall be constructed of ABS, conforming to ASTM-D 1788. Lid top casting shall be cast iron, conforming to ASTM A-48 Class 25, providing magnetic detectability, and be painted black. The lid shall have the word "sewer" cast into it. All components shall be inherently corrosion-resistant to ensure durability in the ground. Curb boxes shall provide height adjustment downward (shorter) from their nominal height.
- 2.04 HIGH DENSITY POLYETHYLENE PIPE (SUPPLIED BY OTHERS):** Pipe shall be have a working pressure of 160 psi minimum and shall be classified SDR per ASTM D 3035.
- 2.05 DEVIATIONS:** If a supplier chooses to submit a bid that does not meet all the requirements of this specification, the bid shall include a written description of the deviation with data that shows the magnitude of the deviation and the justification for the deviation from this specification. The decision to accept material deviating from this specification shall be the responsibility of the **SPECIFYING ENGINEER**.
- 2.06 CERTIFICATION:** The owner or the **SPECIFYING ENGINEER** may request certified lab data to verify the physical properties of the pipe materials supplied under this specification or may take random samples and have them tested by an independent laboratory.
- 2.07 REJECTION:** Polyethylene pipe may be rejected for failure to meet any of the requirements of this specification.
- 2.08 PIPE DIMENSIONS:** The SDR (Standard Dimension Ratio) of the pipe supplied shall be as specified by the **SPECIFYING ENGINEER**. SDR 7, 9 and 11 fittings are available from the **MANUFACTURER**. SDR 7 fittings will not work with SDR pipe.

### **3.0 EXECUTION**

- 3.01 FACTORY TEST:** The Uni-Lateral shall be 100 percent hydrostatically tested to 150 psi in the factory.
- 3.02 CONSTRUCTION PRACTICES:** Pipe shall be stored on clean, level ground to prevent undue scratching or gouging of the pipe. If the pipe must be stacked for storage, such stacking should be in accordance with the pipe manufacturer's recommendations. The pipe should be handled in such a manner that it is not damaged by being dragged over sharp objects or cut by chokers or lifting equipment.

Segments of pipe having cuts or gouges in excess of 10 percent of the wall thickness of the pipe shall be cut out and removed. The undamaged portions of the pipe shall be rejoined using the butt fusion joining method. Sections of polyethylene pipe should be joined into continuous lengths on the job site above ground. The joining method shall be the butt-fusion method and shall be performed in strict accordance with the pipe manufacturer's recommendations. The butt-fusion equipment used in the joining procedure shall be capable of meeting all conditions recommended by the pipe manufacturer, including, but not limited to, fusion temperature, alignment, and fusion pressure.

Fused segments of pipe shall be handled so as to avoid damage to the pipe. When lifting fused sections of pipe, chains or cable-type chokers should be avoided. Nylon slings are preferred. Spreader bars should be used when lifting long, fused sections. Care should be exercised to avoid cutting or gouging the pipe.

- 3.03 INSTALLATION:** Assemble the compression fittings according to the fitting manufacturer's recommendations.

The trench and trench bottom should be constructed in accordance with ASTM D 2321. Embedment materials should be Class I, Class II or Class III materials as defined in ASTM D 2321. The use of Class IV and/or Class V materials for embedment is not recommended and should be allowed only with the approval of the **SPECIFYING ENGINEER**. Bedding of the pipe should be performed in

accordance with ASTM D 2321. Compaction should be as specified in ASTM D 2321. Deviations from the specified compaction shall be approved by the **SPECIFYING ENGINEER**.

Haunching and initial backfill should be as specified in ASTM D 2321 using Class I, Class II or Class III materials. Materials used and compaction shall be as specified by the **SPECIFYING ENGINEER**. In cases where a compaction of 85 percent Standard Proctor Density is not attainable, the **SPECIFYING ENGINEER** may wish to increase the SDR of the pipe to provide adequate stiffness. ASTM D 2321 sections titled "Minimum Cover for Load Application," "Use of Compaction Equipment" and "Removal of Trench Protection" should apply unless directed otherwise by the **SPECIFYING ENGINEER**.

END OF SECTION



Environment One  
2773 Balltown Road  
Niskayuna, New York 12309

# Typical Cleanout Detail

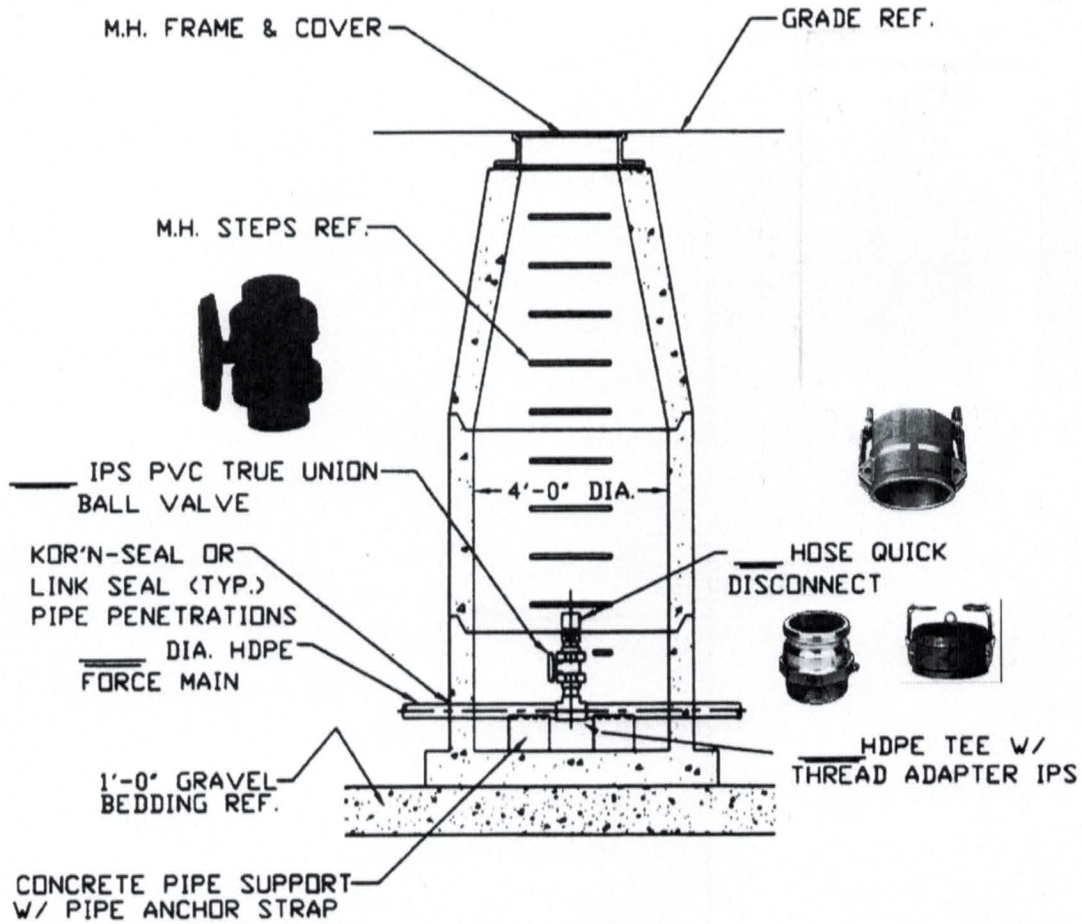

TYPICAL ELEV. VIEW

Cleanout detail can be modified to match typical installation needs. Inline shut offs may be added to isolate flow direction. Image shown is flow through cleanout. These structures can be terminal end of line cleanouts, or junction cleanouts as may be required. Optional air and vacuum relief valves may be added when required.

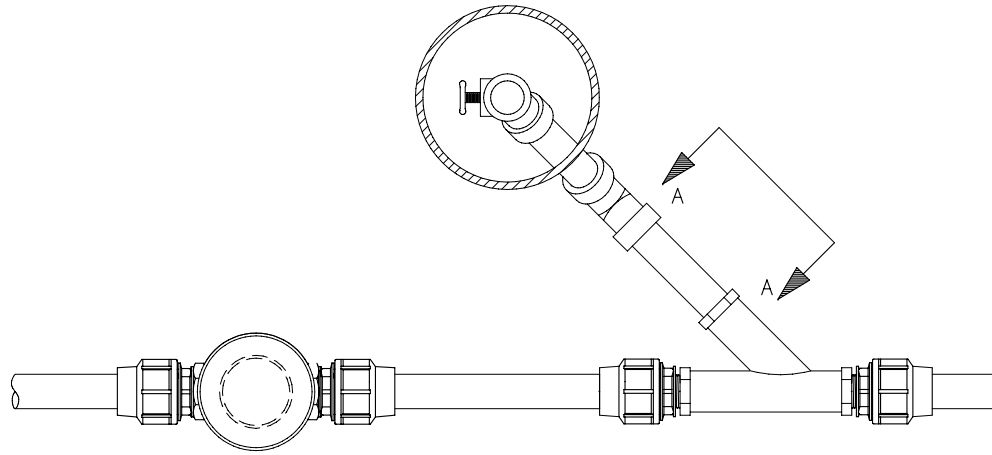

PLAN VIEW

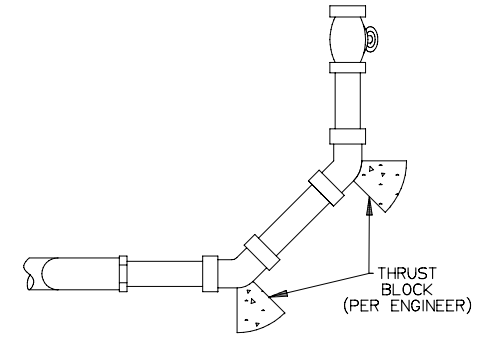

VIEW "A"  
3/4 = 1

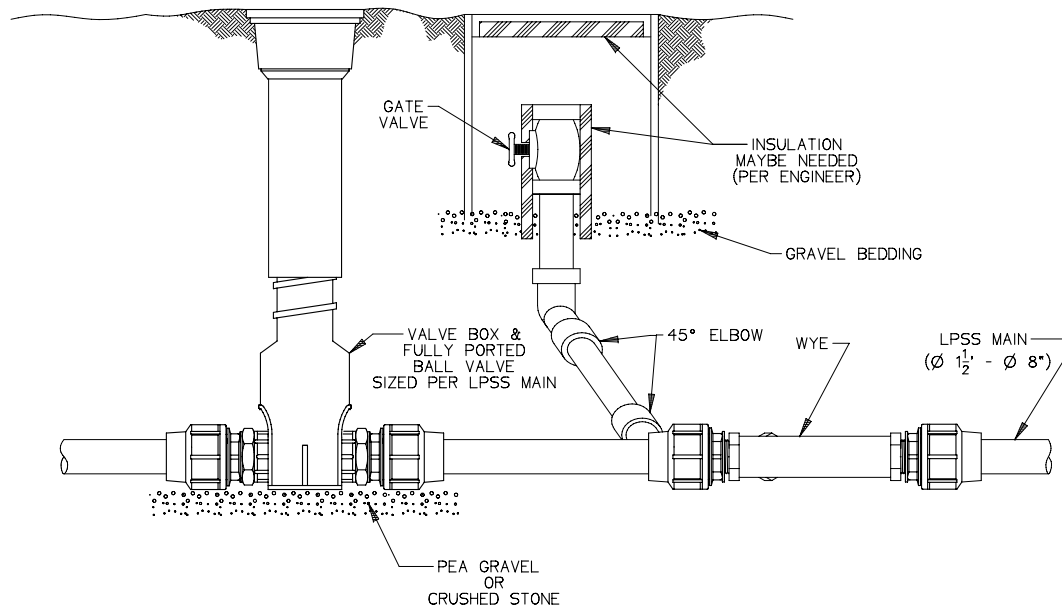

**TYPICAL FLUSHING CONNECTION ON LPSS MAIN**

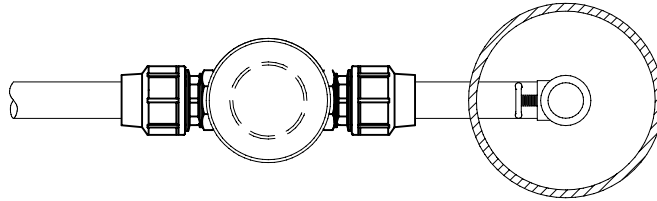

PLAN VIEW

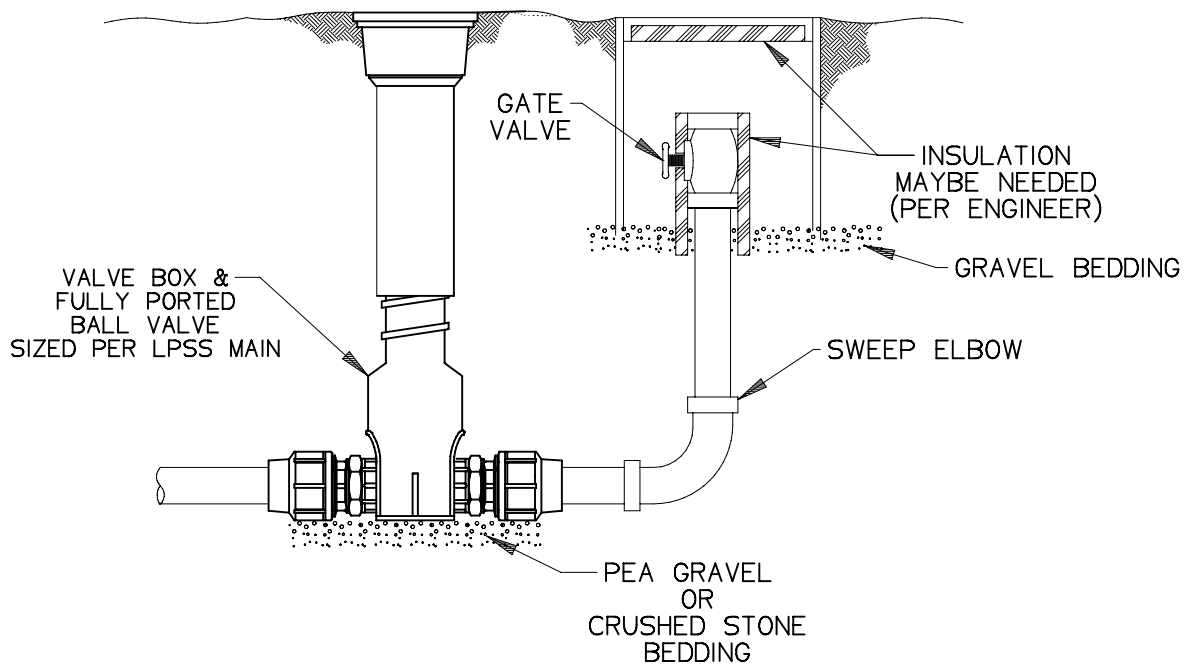

## TYPICAL TERMINAL FLUSHING CONNECTION

SGS		05-13-10	1	1/32
DR BY	CHK'D	DATE	ISSUE	SCALE



TYPICAL TERMINAL  
FLUSHING CONNECTION

ESD 10-0094

\_\_\_\_\_  
Bidder's Name

**Category of  
Exceptions**  
**A B C D**

**SPECIFICATIONS:**

General

All HDPE piping and fittings and other materials listed shall be manufactured in North America and shall contain no lead.

Item 1 – 2” SDR 11 HDPE Low Pressure Sewer Main

Item 2 – 1.25” SDR 11 HDPE Service Lateral Pipe

Item 3 – 90 Degree Elbows for 2” SDR 11 HDPE Low Pressure Sewer Main

Item 4 – Corp Stops

Item 5 – Lateral Kits (Curb Stops) with Curb Boxes

Item 6 - Clean Outs for installation in Sewer Manholes

--	--	--	--